



# VIKAS INDUSTRIES

A GOVT. OF INDIA RECOGNISED STAR EXPORT HOUSE



AN ISO 9001: 2015 CERTIFIED COMPANY  
A UL LISTED COMPANY

## STRUT CLAMP

**MATERIAL** : MILD STEEL

**APPLICATION** : STRUT CLAMPS ARE PREASSEMBLED DEVICES DESIGNED TO SECURE RIGID CONDUIT TO A STRUT CHANNEL IN BOTH OVERHEAD AND WALL MOUNT APPLICATIONS.

**FINISH** : ELECTRIC ZINC PLATED STEEL, HOT DIP GALVANIZED STEEL.

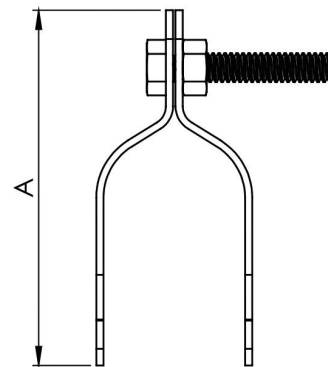
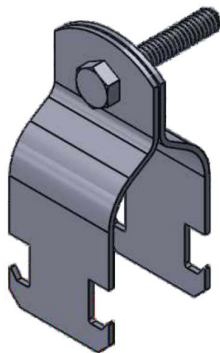

Article No.	Size (Inch)	Length A (mm)	Width (mm)	Bolt Size
VICC-01	1/2"	58	32	M6
VICC-02	3/4"	62	32	M6
VICC-03	1"	68	32	M6
VICC-04	1-1/4"	82	32	M6
VICC-05	1-1/2"	87	32	M6
VICC-06	2"	102	32	M8
VICC-07	2-1/2"	127	32	M8
VICC-08	3"	141	32	M8
VICC-09	3-1/2"	152	32	M10
VICC-10	4"	165	32	M10
VICC-11	5"	176	40	M10
VICC-12	6"	198	40	M10
VICC-13	8"	260	40	M10